

SPECIFICATION FOR
MANGANESE DIOXIDE LITHIUM BATTERY
Type: CR1632-P/H [TOSHIBA Brand]

APPROVED

D e c . 5 . 2 0 1 3

TOSHIBA HOME APPLIANCES CORPORATION
Battery Business Div.

PRODUCT SPECIFICATION

1. Applicability

This specification is applicable to the following product to deliver to TOSHIBA HOME APPLIANCES CORPORATION :
Coin Type Manganese Dioxide Lithium Battery **CR1632**

2. Model Name and Performance

- | | |
|---------------------------|---|
| 2.1 Model Name | CR1632-P/H |
| 2.2 Nominal Voltage | 3 V |
| 2.3 Nominal Capacity | 140 mAh (Load Resistance: 15 k Ω , Cutoff Voltage:2.0 V) |
| 2.4 Operating Temperature | -20 ~65°C |
| 2.5 Nominal Mass | Approx. 2.0 g |
| 2.6 External Dimension | Shape and dimensions shall be as shown in Figure 1. |
| 2.7 Chemical System | Anode : Lithium
Cathode : Manganese Dioxide
Electrolyte : Organic Solvent with Lithium Salt |

3. Characteristic

- | | |
|------------------------------|---|
| 3.1 Open-Circuit Voltage | The characteristics shown below in Table 1 should be satisfied. |
| 3.2 Impedance | The characteristics shown below in Table 1 should be satisfied. |
| 3.3 Duration | The characteristics shown below in Table 1 should be satisfied. |
| 3.4 Duration (Acceleration) | The characteristics shown below in Table 1 should be satisfied. |
| 3.5 Leakage | The characteristics shown below in Table 1 should be satisfied. |
| 3.6 Appearance | There shall be no remarkable defects that could deteriorate reliability such as scratches, stains, deformation, and leakage. |
| 3.7 Use recommendation limit | It makes 5 years after battery manufacture.
It makes the standard of the unit the moon and it counts from the first half manufacture date of it. |
| 3.8 UL Approval | Lithium Manganese Dioxide Batteries are approved by UL1642. |

(Table 1) Characteristics

No	Test Item		Characteristic		Test Condition
			Initial*1	After 1 Year	
1	Open-Circuit Voltage	20°C	3.00 ~3.40 V	3.00 ~3.40 V	
2	Closed-Circuit Voltage	20°C	3.00 ~3.40 V	3.00 ~3.40 V	Load Resistance:15kΩ 0.8s
3	Duration	60°C	590 h minimum	—	Load Resistance: 15k Ω Cutoff Voltage: 2.0 V
		20°C	660 h minimum	650 h minimum	
		0°C	480 h minimum	—	
4	Duration (Acceleration)	20°C	650 h minimum		After storage at 60°C for 20 days Load Resistance: 15k Ω Cutoff Voltage: 2.0 V
			594 h minimum		After storage at 60°C for 100 days (Equivalent to storage at room temperature for 5 years) Load Resistance: 15k Ω Cutoff Voltage: 2.0 V
5	Leakage		No leakage being obstacles to practical use.		After storage at 60°C for 30 days

*1 Initial: within 1 month after delivery.

4. Test

4.1 Test Condition and Storage Condition

4.1.1 Test Condition

Tests shall be done at $20\pm 2^{\circ}\text{C}$ with $(65\pm 15)\%$ R.H. unless particularly specified.

4.1.2 Storage Condition

Storage shall be done at $20\pm 2^{\circ}\text{C}$ with $(65\pm 15)\%$ R.H. unless particularly specified.

4.2 Test Instrument or Apparatus

4.2.1 Dimension Measuring Instrument

Instruments should be micrometers and dial gauges with minimum reading of 0.01mm or those that have the equal or more accuracy. Overall height shall be measured with insulator between measured faces.

4.2.2 Voltmeter

Tolerance: within $\pm 0.005\text{V}$, Input Resistance: $1\text{M}\ \Omega$ min.

4.2.3 Load Resistance

Load resistance shall include all resistance of external circuits, and the tolerance shall be 0.5% or less.

4.3 Test Procedure

4.3.1 Dimension

Dimensions shall be measured with dimension measuring instruments specified in Item 4.2.1.

4.3.2 Open-Circuit Voltage

After storage at $20\pm 2^{\circ}\text{C}$ for more than 2 hours, the battery shall be measured with the voltmeter specified in Item 4.2.2 at the same temperature.

4.3.3 Duration

After storage at each specified temperature ($60\pm 2^{\circ}\text{C}$, $20\pm 2^{\circ}\text{C}$, and $0\pm 2^{\circ}\text{C}$) for more than 8 hours, the battery shall be discharged under the conditions specified in Table 1 at the same temperature. The time when the closed-circuit voltage drops below the cutoff voltage in Table 1 is defined as the end time of discharge.

4.3.4 Duration (Acceleration)

After storage at $60\pm 2^{\circ}\text{C}$ for the period of time specified in Table 1 and then at $20\pm 2^{\circ}\text{C}$ for more than 8 hours, the battery shall be discharged under the conditions specified in Table 1. The time when the closed-circuit voltage drops below the cutoff voltage in Table 1 is defined as the end time of discharge.

4.3.5 Leakage

After storage at $60\pm 2^{\circ}\text{C}$ for the period of time specified in Table 1, leakage shall be visually inspected.

4.3.6 Appearance

Appearance shall be visually inspected.

5. Markings on batteries

5.1 Battery system

L I T H I U M B A T T E R Y

5.2 Model Name

C R 1 6 3 2

5.3 Brand of battery

T O S H I B A

5.4 Polarity

+ (- s h a l l n o t b e i n d i c a t e d)

5.5 Nominal voltage

3 V

5.6 Manufacturing code

The year and month of production shall be marked on the negative(-)terminal side.

The manufacturing code displays it in the place except a radius of 3mm from the center of the negative terminal side.

[Example] **3 2 P** . . . Manufactured in February 2013

3 X P . . . Manufactured in October 2013

6. Warranty term

12 months after delivery.

(Figure 1) DIMENSION

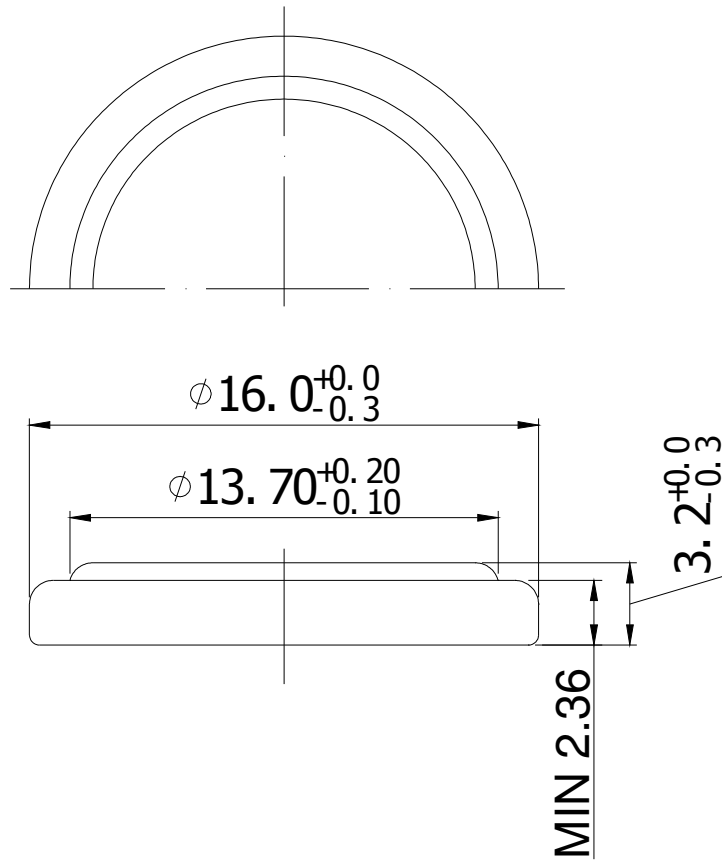

(Unit: mm)

Precautions in Designing a Memory Backup Circuit

Lithium battery has acquired safety Standard of UL.

Connect a diode and resistor in series with the battery to prevent charging current and to limit the maximum current drain.

Note that, under the particular fault condition of the series diode becoming short circuit, the charging current must not exceed 2.5 mA.

The leakage current of reverse-flow preventing diode shall be designed to be within 2% of battery's nominal capacity to the whole operating term.

Acquired Safety Standard : UL1642

